

# Dell PowerConnect W-AP90 Series Access Point

## Installation Guide

### About the Dell W-AP90 Series

The Dell W-AP90 Series APs are single-radio, dual-band wireless access points that support the IEEE 802.11n standard for high-performance WLAN. These access points use MIMO (Multiple-in, Multiple-out) technology and other high-throughput mode techniques to deliver high-performance, 802.11n 2.4 GHz or 5 GHz functionality while simultaneously supporting existing 802.11a/b/g wireless services. The W-AP90 Series access points work only in conjunction with a Dell Controller.

The Dell W-AP90 Series access point provides the following capabilities:

- Wireless transceiver
- Protocol-independent networking functionality
- IEEE 802.11a/b/g/n operation as a wireless access point
- IEEE 802.11a/b/g/n operation as a wireless air monitor
- Compatibility with IEEE 802.3af PoE
- Central management configuration and upgrades through a Dell Controller

### Package Contents

- W-AP92 or W-AP93 access point
- Installation Guide



**Note:** Inform your supplier if there are any incorrect, missing, or damaged parts. If possible, retain the carton, including the original packing materials. Use these materials to repack and return the unit to the supplier if needed.

Figure 1 W-AP90 Series (AP-92 Shown)

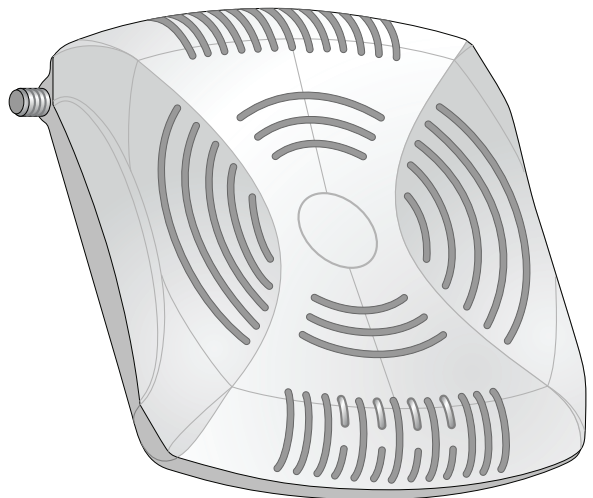

### W-AP90 Series Hardware Overview

Figure 2 Front (W-AP92 Shown)

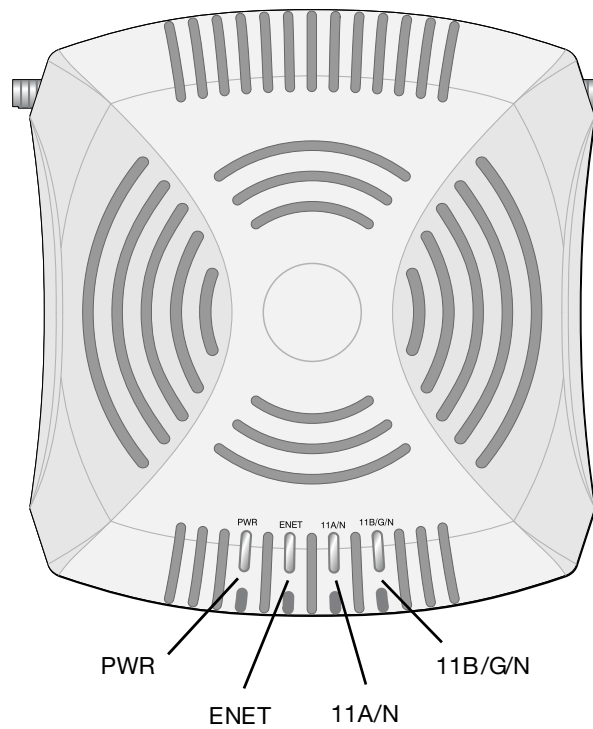

#### LEDs

- PWR: Indicates whether or not the AP is powered-on
- ENET: Indicates the status of the AP's Ethernet port
- 11A/N: Indicates the status of the 802.11a/n radio
- 11B/G/N: Indicates the status of the 802.11b/g/n radio

For information about the AP's LED behavior, see [Table 1](#).

Figure 3 Rear (W-AP92 Shown)

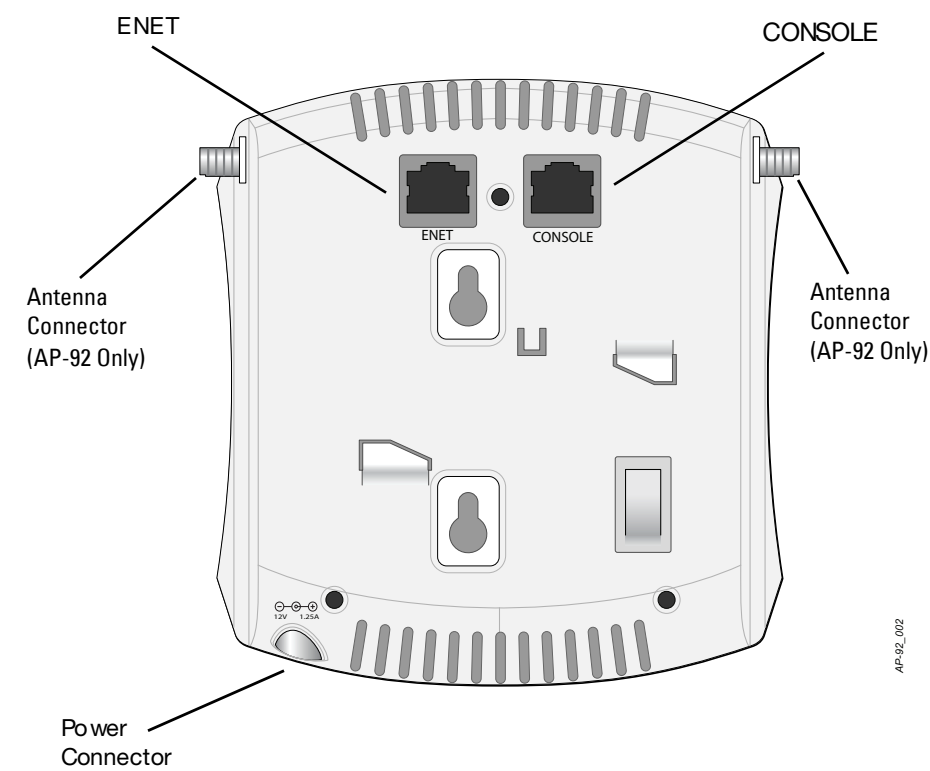

#### Console Port

Use the console port to connect to a terminal for direct local management.

#### Ethernet Port

The W-AP90 Series is equipped with a single 10/100/1000Base-T (RJ-45) auto-sensing, MDI/MDX wired-network connectivity port. This port supports IEEE 802.3af Power over Ethernet (PoE) compliance, accepting 48VDC as a standard defined Powered Device (PD) from a Power Sourcing Equipment (PSE) such as a PoE midspan injector, or network infrastructure that supports PoE.

#### DC Power Socket

If PoE is not available, an optional Dell AP AC-DC adapter kit (sold separately) can be used to power the AP.

#### External Antenna Connectors

The W-AP92 is designed for use with external antennas. The W-AP93 is equipped with internal antennas.

### Before You Begin



**Caution: FCC Statement:** Improper termination of access points installed in the United States configured to non-US model controllers will be in violation of the FCC grant of equipment authorization. Any such willful or intentional violation may result in a requirement by the FCC for immediate termination of operation and may be subject to forfeiture (47 CFR 1.80).



**Caution: EU Statement:** Lower power radio LAN product operating in 2.4 GHz and 5 GHz bands. Please refer to the *ArubaOS User Guide* for details on restrictions.



Produit réseau local radio basse puissance operant dans la bande fréquence 2.4 GHz et 5 GHz. Merci de vous référer au *ArubaOS User Guide* pour les détails des restrictions.

Low Power FunkLAN Produkt, das im 2.4 GHz und im 5 GHz Band arbeitet. Weitere Informationen bezüglich Einschränkungen finden Sie im *ArubaOS User Guide*.

Apparati Radio LAN a bassa Potenza, operanti a 2.4 GHz e 5 GHz. Fare riferimento alla *ArubaOS User Guide* per avere informazioni dettagliate sulle restrizioni.

#### Pre-Installation Network Requirements

After WLAN planning is complete and the appropriate products and their placement have been determined, the Dell controller(s) must be installed and initial setup performed before the Dell APs are deployed.

For initial setup of the controller, refer to the *ArubaOS Quick Start Guide* for the software version installed on your controller.

#### AP Pre-Installation Checklist

Before installing your W-AP90 Series access point, be sure that you have the following:

- CAT5 UTP cable of required length
- One of the following power sources:
  - IEEE 802.3af-compliant Power over Ethernet (PoE) source
  - Dell AP AC-DC adapter kit (sold separately)
- Dell Controller provisioned on the network:
  - Layer 2/3 network connectivity to your access point

One of the following network services:

- Dell Discovery Protocol (ADP)
- DNS server with an "A" record
- DHCP Server with vendor-specific options

#### Summary of the Setup Process



**Note:** It is important that you verify the items listed under **AP Pre-Installation Checklist** before you attempt to set up and install an W-AP90 Series.

Successful setup of an W-AP90 Series access point consists of five tasks, which must be performed in this order:

1. Verify pre-installation connectivity.
2. Identify the specific installation location for each AP.
3. Install each AP.
4. Verify post-installation connectivity.
5. Configure each AP.



**Note:** Dell, in compliance with governmental requirements, has designed the W-AP90 Series access points so that only authorized network administrators can change the settings. For more information about AP configuration, refer to the *ArubaOS Quick Start Guide* and *ArubaOS User Guide*.



**Caution:** Access points are radio transmission devices and as such are subject to governmental regulation. Network administrators responsible for the configuration and operation of access points must comply with local broadcast regulations. Specifically, access points must use channel assignments appropriate to the location in which the access point will be used.

#### Verifying Pre-Installation Connectivity

Before you install APs in a network environment, make sure that the APs are able to locate and connect to the controller after power on. Specifically, you must verify the following conditions:

- When connected to the network, each AP is assigned a valid IP address
- APs are able to locate the controller

Refer to the *ArubaOS Quick Start Guide* for instructions on locating and connecting to the controller.

#### Identifying Specific Installation Locations

You can mount the W-AP90 Series access point on a wall or on the ceiling. Use the AP placement map generated by Dell's RF Plan software application to determine the proper installation location(s). Each location should be as close as possible to the center of the intended coverage area and should be free from obstructions or obvious sources of interference. These RF absorbers/reflectors/interference sources will impact RF propagation and should have been accounted for during the planning phase and adjusted for in RF plan.

#### Identifying Known RF Absorbers/Reflectors/Interference Sources

Identifying known RF absorbers, reflectors, and interference sources while in the field during the installation phase is critical. Make sure that these sources are taken into consideration when you attach an AP to its fixed location.

RF absorbers include:

- Cement/concrete—Old concrete has high levels of water dissipation, which dries out the concrete, allowing for potential RF propagation. New concrete has high levels of water concentration in the concrete, blocking RF signals.
- Natural Items—Fish tanks, water fountains, ponds, and trees
- Brick

RF reflectors include:

- Metal Objects—Metal pans between floors, rebar, fire doors, air conditioning/heating ducts, mesh windows, blinds, chain link fences (depending on aperture size), refrigerators, racks, shelves, and filing cabinets.
- Do not place an AP between two air conditioning/heating ducts. Make sure that APs are placed below ducts to avoid RF disturbances.

RF interference sources include:

- Microwave ovens and other 2.4 or 5 GHz objects (such as cordless phones)
- Cordless headset such as those used in call centers or lunch rooms

### Installing the AP



**Caution:** Installation and service of Dell Networks products should be performed by Professional Installers. Additional antenna and transmit power information for Professional Installers can be found at <https://support.arubanetworks.com>.



**Note:** If you are installing an W-AP92, be sure to attach the antennas before mounting the AP.

#### Using the Integrated Wall-Mounting Slots

The keyhole-shaped slots on the back of the AP can be used to attach the device upright to an indoor wall or shelf. When you choose the mounting location, allow additional space at the right of the unit for cables.

1. Since the ports are on the back of the device, make sure that you mount the AP in such a way that there is a clear path to the Ethernet port, such as a pre-drilled hole in the mounting surface.
2. At the mounting location, install two screws on the wall or shelf, 1 7/8 inches (4.7 cm) apart. If you are attaching the device to drywall, Dell recommends using appropriate wall anchors (not included).
3. Align the mounting slots on the rear of the AP over the screws and slide the unit into place (see [Figure 4](#)).

Figure 4 Installing the W-AP90 Series Access Point on a Wall

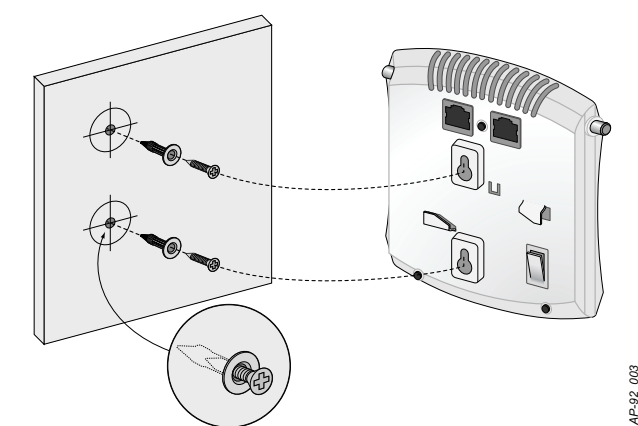

#### Using the Integrated Ceiling Tile Rail Slots

The snap-in tile rail slots on the rear of the AP can be used to securely attach the device directly to a 15/16" wide, standard ceiling tile rail.



**Caution:** Make sure the AP fits securely on the ceiling tile rail when hanging the device from the ceiling; poor installation could cause it to fall.

1. Pull the necessary cables through a prepared hole in the ceiling tile near where the AP will be placed.
2. If necessary, connect the console cable to the console port on the back of the AP.
3. Hold the AP next to the ceiling tile rail with the ceiling tile rail mounting slots at approximately a 30-degree angle to the ceiling tile rail (see [Figure 5](#)). Make sure that any cable slack is above the ceiling tile.



**Figure 5** Orienting the Ceiling Tile Rail Mounting Slots

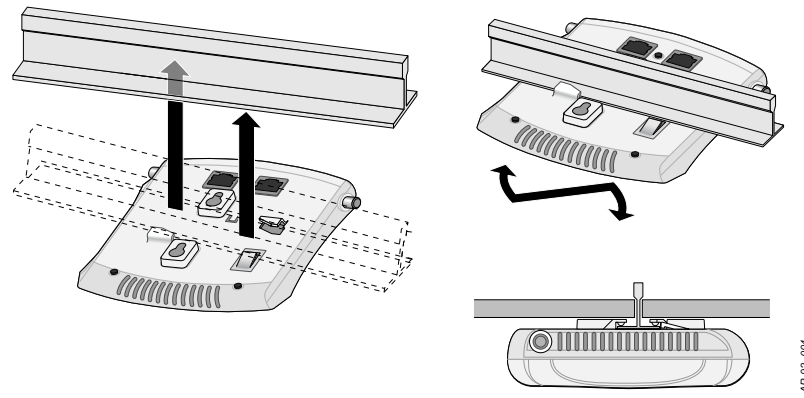

- Pushing toward the ceiling tile, rotate the AP clockwise until the device clicks into place on the ceiling tile rail.

### Connecting Required Cables

Install cables in accordance with all applicable local and national regulations and practices.

### Ethernet Ports

The RJ45 Ethernet port (ENET) supports 10/100/1000Base-T auto-sensing MDI/MDX connections. Use these ports to connect the AP to a twisted pair Ethernet LAN segment or directly to an Dell Controller. Use a 4- or 8-conductor, Category 5 UTP cable up to 100 m (325 feet) long.

The 10/100/1000 Mbps Ethernet port is on the back of the AP. The port has an RJ-45 female connector with the pin-outs shown in .

**Figure 6** Gigabit Ethernet Port Pin-Out

1000Base-T Gigabit Ethernet Port	RJ-45 Female Pin-Out	Signal Name	Function
	1	BI_DA+	Bi-directional pair +A
	2	BI_DA-	Bi-directional pair -A
	3	BI_DB+	Bi-directional pair +B
	4	BI_DC+	Bi-directional pair +C
	5	BI_DC-	Bi-directional pair -C
	6	BI_DB-	Bi-directional pair -B
	7	BI_DD+	Bi-directional pair +D
	8	BI_DD-	Bi-directional pair -D

### Serial Console Port

The serial console port (Console) allows you to connect the AP to a serial terminal or a laptop for direct local management. This port is an RJ-45 female connector with the pinouts described in Figure 7. Connect this port directly to a terminal or terminal server using an Ethernet cable.

Use a modular adapter to convert the RJ-45 (female) connector on the AP to a DB-9 (male) connector, and connect the adapter to a laptop using an RS-232 cable. See Figure 8 for connector details of the adapter.

**Figure 7** Serial Port Pin-Out

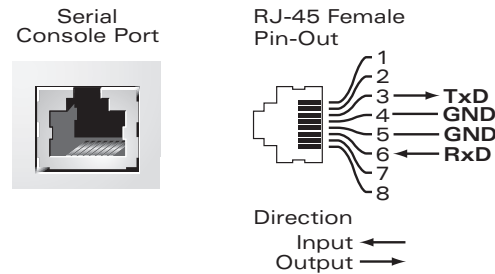

**Figure 8** RJ-45 (Female) to DB-9 (Male) Modular Adapter Conversion

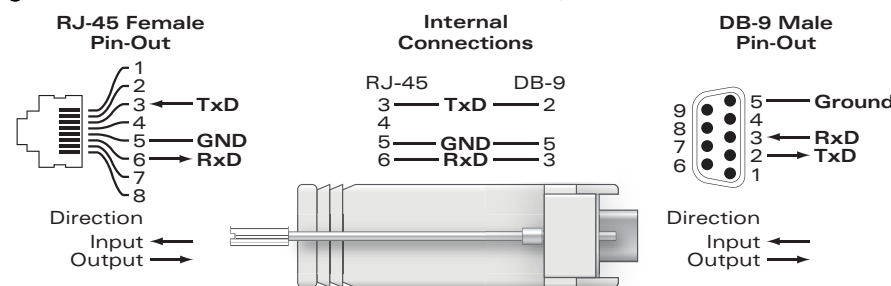

### Power Connection

The W-AP90 Series has a single 12V DC power jack socket to support powering through an AC-to-DC power adapter.



**Note:** If both POE and DC power are available, the AP uses POE even when there is not enough POE voltage available to power the AP.

## Verifying Post-Installation Connectivity

The integrated LEDs on the AP can be used to verify that the AP is receiving power and initializing successfully (see Table 1). Refer to the *ArubaOS Quick Start Guide* for further details on verifying post-installation network connectivity

LED	Color/State	Meaning
PWR	Off	No power to AP
	Green flashing	System initializing
	Red steady	System failed to initialize, contact TAC
	Green steady	Power on, device ready
ENET (10/100/1000 Mbps)	Off	No link
	Green on	1000 Mbps link
	Amber on	10/100 Mbps link
11A/N	Off	5 GHz radio is disabled
	Amber	5 GHz radio enabled in WLAN mode
	Green	5 GHz radio enabled in 11n mode
	Green flashing	5 GHz Air Monitor or RF Protect mode
11B/G/N	Off	2.4 GHz radio disabled
	Amber	2.4 GHz radio enabled in WLAN mode
	Green	2.4 GHz radio enabled in 11n mode
	Green flashing	2.4 GHz Air Monitor or RF Protect mode

## Configuring the W-AP90 Series

### AP Provisioning/Reprovisioning

Provisioning parameters are unique to each AP. These local AP parameters are initially configured on the controller which are then pushed out to the AP and stored on the AP itself. Dell recommends that provisioning settings be configured via the ArubaOS Web UI only. Refer to the *ArubaOS User Guide* for complete details.

### AP Configuration

Configuration parameters are network or controller specific and are configured and stored on the controller. Network configuration settings are pushed out to the AP(s) but remain stored on the controller.

Configuration settings can be configured via the ArubaOS Web UI, ArubaOS CLI, or Dell MMS. Refer to their respective guides for further details: the *ArubaOS User Guide* or *Dell Mobility Management System User Guide*.

## Product Specifications

### Mechanical

- Dimensions (HxWxD):
  - 4.7 inches x 5.1 inches x 1.4 inches (12.0 cm x 13.0 cm x 3.5 cm)
- Weight: 375g/0.82 lbs.
- Operating Temperature: 0°C to 50°C (32°F to 122°F)
- Storage Temperature: -10°C to 70°C (14°F to 158°F)
- Relative Humidity: 5% to 95% non-condensing
- Altitude: 3,000 m @ 50°C (122°F)
- Mounting: Wall or ceiling
- Visual Status Indicators (LEDs): See Table 1

### Electrical

- Ethernet:
  - 1 x 10/100/1000Base-T auto-sensing Ethernet RJ-45 Interfaces
  - MDI/MDX
  - IEEE 802.3 (10Base-T), IEEE 802.3u (100Base-T), IEEE 802.3ab (1000Base-T)
  - Power over Ethernet (IEEE 802.3af compliant), 48V DC/350mA (see Figure 6 for pin configuration)
- Power:

- 12 VDC power interface, supports powering through an AC-to-DC power adapter



**Note:** If a power adapter other than the one provided by Dell Networks is used in the US or Canada, it should be cULus (NRTL) Listed, with an output rated 12 VDC, minimum 1.25A, marked "LPS" or "Class 2," and suitable for plugging into a standard power receptacle in the US and Canada.

### Wireless LAN

- Network Standards: IEEE 802.11b, IEEE 802.11g, IEEE 802.11a, and IEEE 802.11n (draft)
  - 2x dual-band antenna connectors (RP-SMA)
- Antenna Type (W-AP92):
  - 2x 802.11a/b/g/n, internal
- Antenna Type (W-AP93):
  - 2.4 – 2.5 GHz/2.5 dBi (max)
  - 5.180 – 5.825 GHz/5.8 dBi (max)
- Radio Technology
  - Orthogonal Frequency Division Multiplexing (OFDM)
  - Direct Sequence Spread Spectrum (DSSS)
- Radio Modulation Type:
  - 802.11b - CCK, BPSK, QPSK
  - 802.11g - CCK, BPSK, QPSK, 16-QAM, 64-QAM
  - 802.11a - BPSK, QPSK, 16-QAM, 64-QAM
  - 802.11n draft 2.0
- Media Access Control: CSMA/CA with ACK
- Supported Frequency Bands 2.4GHz:
  - 2.400 ~ 2.4835GHz (Global), channels country specific
- Supported Frequency Bands 5GHz:
  - 5.150 ~ 5.250GHz (low band), country-specific
  - 5.250 ~ 5.350GHz (mid band), country-specific
  - 5.470 ~ 5.725GHz (Europe), country-specific
  - 5.725 ~ 5.825GHz (high band), country-specific
- Data Rates:
  - 802.11b - 1, 2, 5.5, 11 Mbps per channel
  - 802.11g - 6, 9, 12, 18, 24, 36, 48 and 54 Mbps per channel
  - 802.11a - 6, 9, 12, 18, 24, 36, 48 and 54 Mbps per channel
  - 802.11n - Data rate MCS0 – MCS15 (from 6.5 Mbps to 300 Mbps)

## Proper Disposal of Dell Equipment

For the most current information on Global Environmental Compliance and Dell products please refer to the *Dell PowerConnect W-Series Safety, Environmental, and Regulatory Information* document or see our website at [www.dell.com](http://www.dell.com).

### European Union RoHS

Dell products also comply with the EU Restriction of Hazardous Substances Directive 2002/95/EC (RoHS). EU RoHS restricts the use of specific hazardous materials in the manufacture of electrical and electronic equipment. Specifically, restricted materials under the RoHS Directive are Lead (including Solder used in printed circuit assemblies), Cadmium, Mercury, Hexavalent Chromium, and Bromine. Some Dell products are subject to the exemptions listed in RoHS Directive Annex 7 (Lead in solder used in printed circuit assemblies). Products and packaging will be marked with the "RoHS" label shown at the left indicating conformance to this Directive.

### Safety and Regulatory Compliance

Dell provides a multi-language document containing country specific restrictions and additional safety and regulatory information for all Dell hardware products. The *Dell PowerConnect W-Series Safety, Environmental, and Regulatory Information* document is included with this product.



**Caution:** Dell access points must be installed by a professional installer. The professional installer is responsible for ensuring that grounding is available and it meets applicable local and national electrical codes.



**Caution: RF Radiation Exposure Statement:** This equipment complies with FCC RF radiation exposure limits. This equipment should be installed and operated with a minimum distance of 7.87 inches (20cm) between the radiator and your body for 2.4 GHz and 5 GHz operations. This transmitter must not be co-located or operating in conjunction with any other antenna or transmitter. When operated in the 5.15 to 5.25 GHz frequency range, this device is restricted to indoor use.

# Dell PowerConnect W-AP90 Series Access Point Installation Guide



### Contacting Support

#### Web Site Support

Main Site	<a href="http://www.dell.com">www.dell.com</a>
Support Site	<a href="https://support.dell.com">https://support.dell.com</a>
Dell Documentation	<a href="https://support.dell.com/manuals">https://support.dell.com/manuals</a>

### Copyright

© 2010 Aruba Networks, Inc. AirWave®, Aruba Networks®, Aruba Mobility Management System®, and other registered marks are trademarks of Aruba Networks, Inc. Dell™, the DELL™ logo, and PowerConnect™ are trademarks of Dell Inc.

All rights reserved. Specifications in this manual are subject to change without notice.

Originated in the USA. Any other trademarks appearing in this manual are the property of their respective companies.

### Open Source Code

Certain Aruba products include Open Source software code developed by third parties, including software code subject to the GNU General Public License (GPL), GNU Lesser General Public License (LGPL), or other Open Source Licenses. The Open Source code used can be found at this site:

[http://www.arubanetworks.com/open\\_source](http://www.arubanetworks.com/open_source)

### Legal Notice

The use of Aruba Networks, Inc. switching platforms and software, by all individuals or corporations, to terminate other vendors' VPN client devices constitutes complete acceptance of liability by that individual or corporation for this action and indemnifies, in full, Aruba Networks, Inc. from any and all legal actions that might be taken against it with respect to infringement of copyright on behalf of those vendors.